

215408 - Cremonese A-B Multi Matic 1350 E15 variabile con 1 fungo HBB 901-1.350 argento

Disegni tecnici

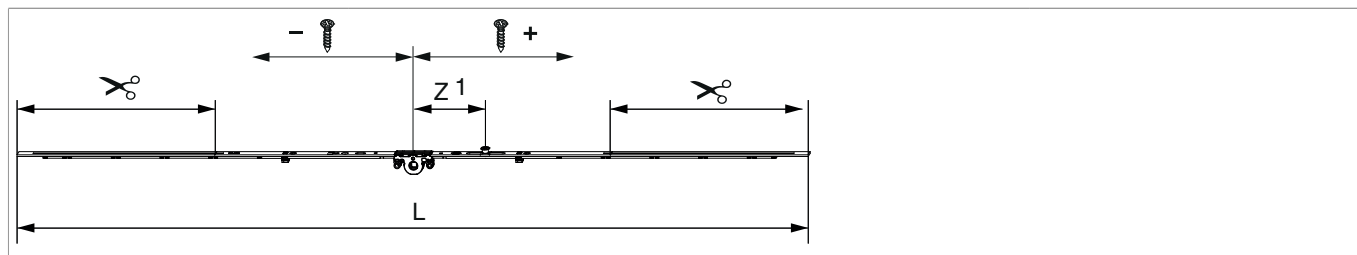

argento	1350	L 1.140	15	901 - 1.350	260	20	215408

Tabella posizionamento viti

		1	2	3	4	5	6	7	8
215408	3	-206,5	129,5	199					

Tabella punti di chiusura

		Z1	Z2	Z3
215408	1	95		

Dime

Dima forature per fori martellina MM	per punta 3mm	1	203861
Dima forature per fori martellina MM	per punta D=3 mm e D=12 mm	1	203862

Quote della scatola cremonese

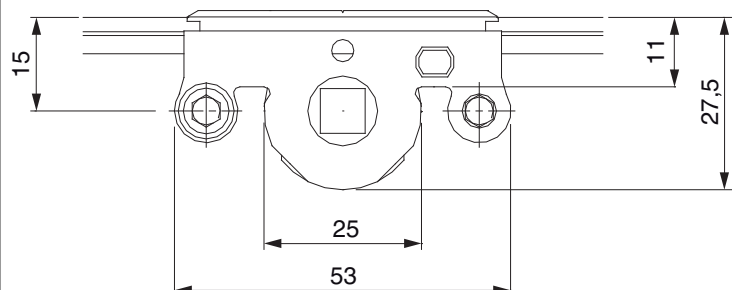

- Larghezza fresata per scatola cremonese 12 mm
- Per fissaggio maniglia utilizzare viti SPAX Ø 5 mm o viti M5.

Schema di fresata

per PVC e alluminio

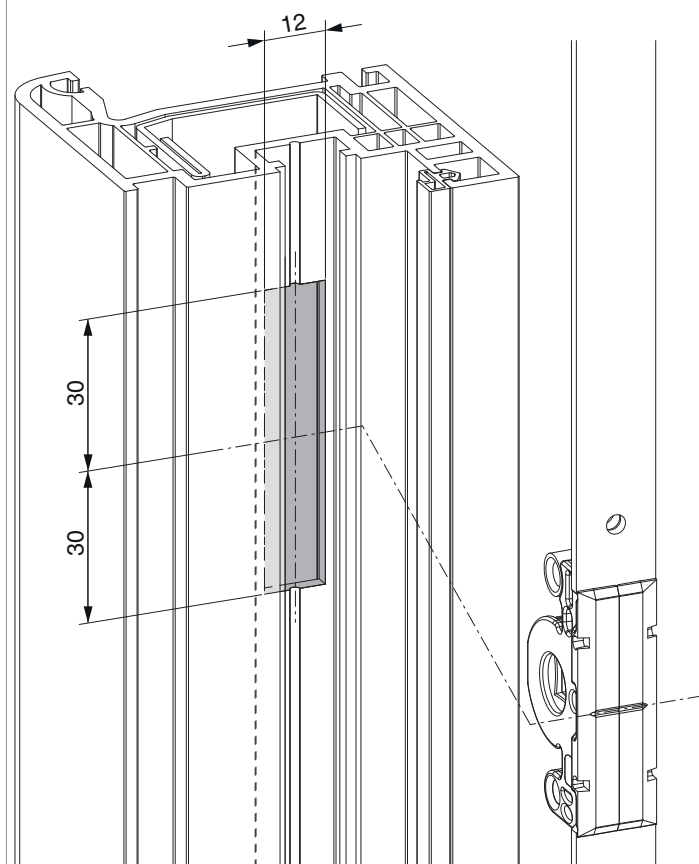

Schema di foratura

Per serramenti in legno

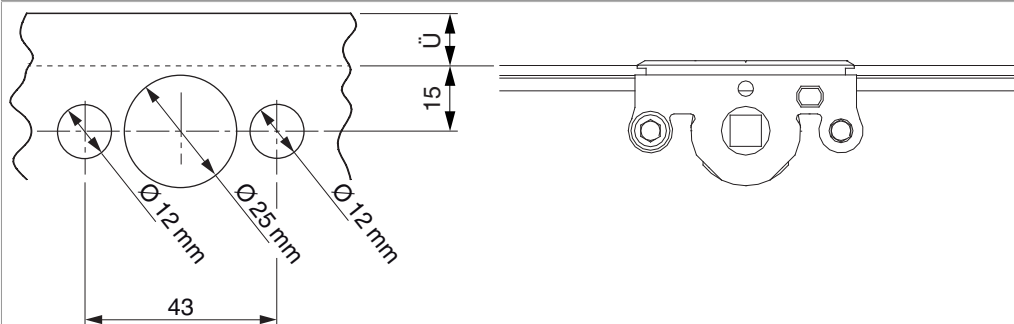

Per serramenti in PVC e alluminio

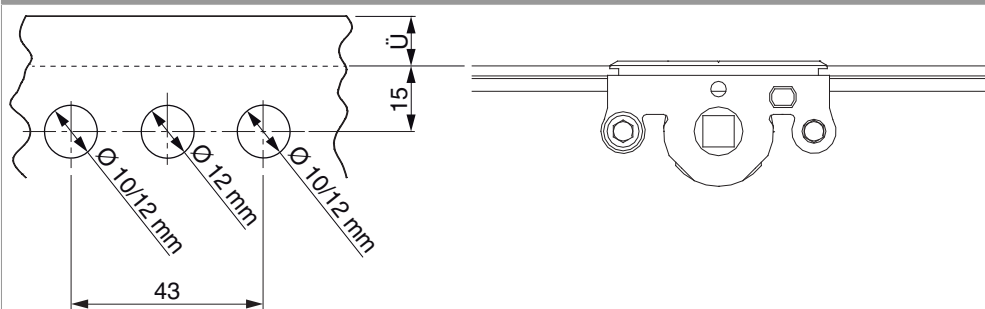

Schema di tranciatura

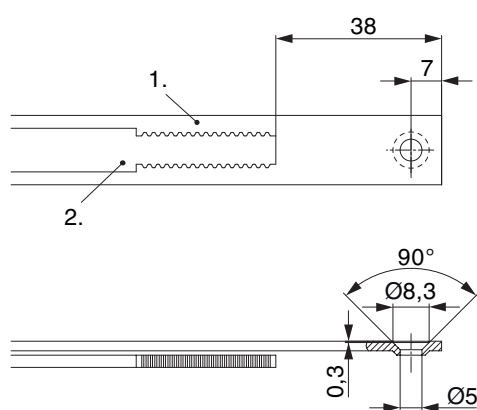

• Consigliamo di trattare il taglio dei componenti TRICOAT-PLUS con la vernice di ritocco TRICOAT-PLUS (cod. 358440).

1. Frontale
2. Asta mobile

Collegamento scarpetta dentata

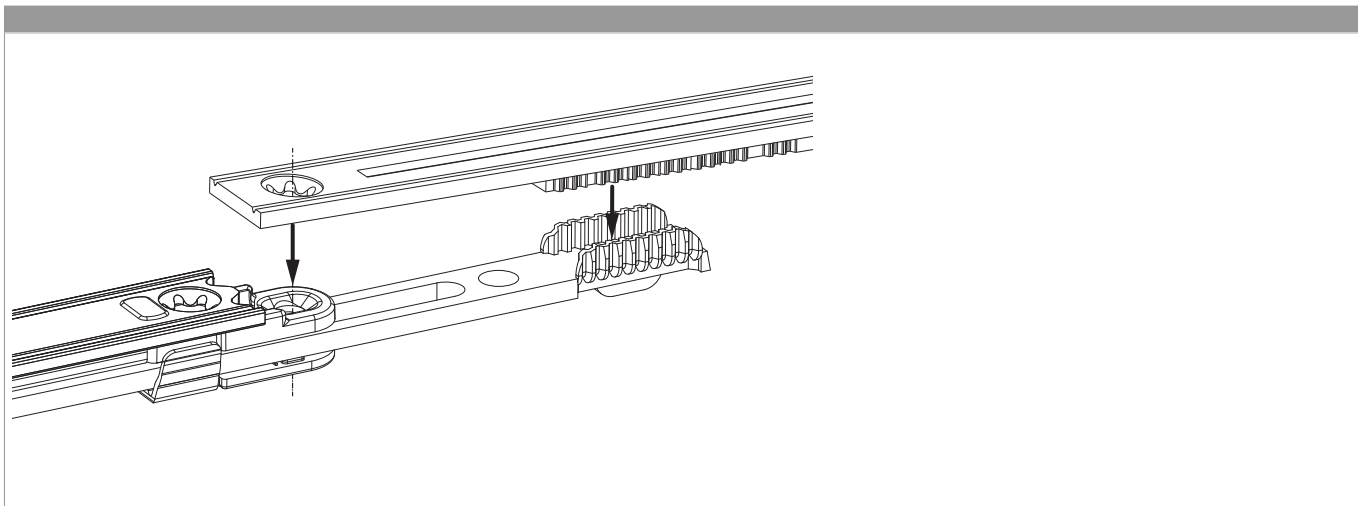

Regolazione pressione

Fungo e nottolino

