

205630 - Cremonese Multi Matic 2450 E35 fix bloccabile con cilindro con 4 funghi HBB 2.201-2.450 HM1.050 argento

Disegni tecnici

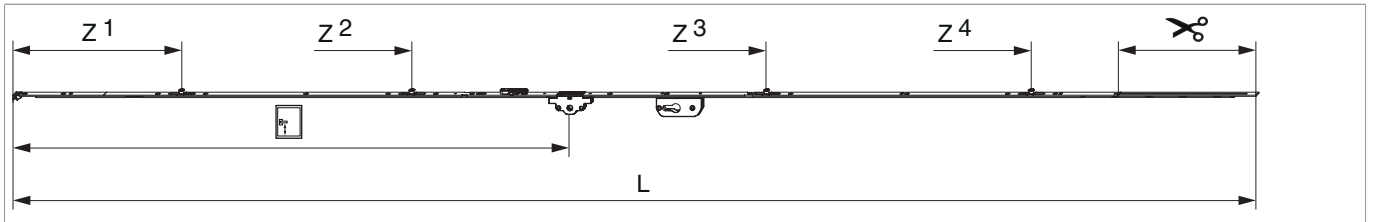

| | | | | | | | L | | N ^o |
|---------|------|----|-------|---------------|-------|---|---------|----|----------------|
| argento | 2450 | 35 | 1.050 | 2.201 - 2.450 | 260,5 | 1 | 2.346,5 | 10 | 205630 |

Tabella posizionamento viti

| N ^o | | 1 | 2 | 3 | 4 | 5 | 6 | 7 | 8 | 9 | 10 | 11 | 12 | 13 | 14 |
|----------------|----|------|------|-----|-----|-----|-----|-----|-------|-------|-------|-------|-------|-------|-------|
| 205630 | 14 | 18,5 | 91,5 | 270 | 360 | 550 | 705 | 795 | 863,5 | 1.124 | 1.388 | 1.465 | 1.685 | 1.875 | 1.965 |

Tabella punti di chiusura

| N ^o | | Z1 | Z2 | Z3 | Z4 |
|----------------|---|-----|-----|-------|-------|
| 205630 | 4 | 315 | 750 | 1.420 | 1.920 |

Quote della scatola cremonese

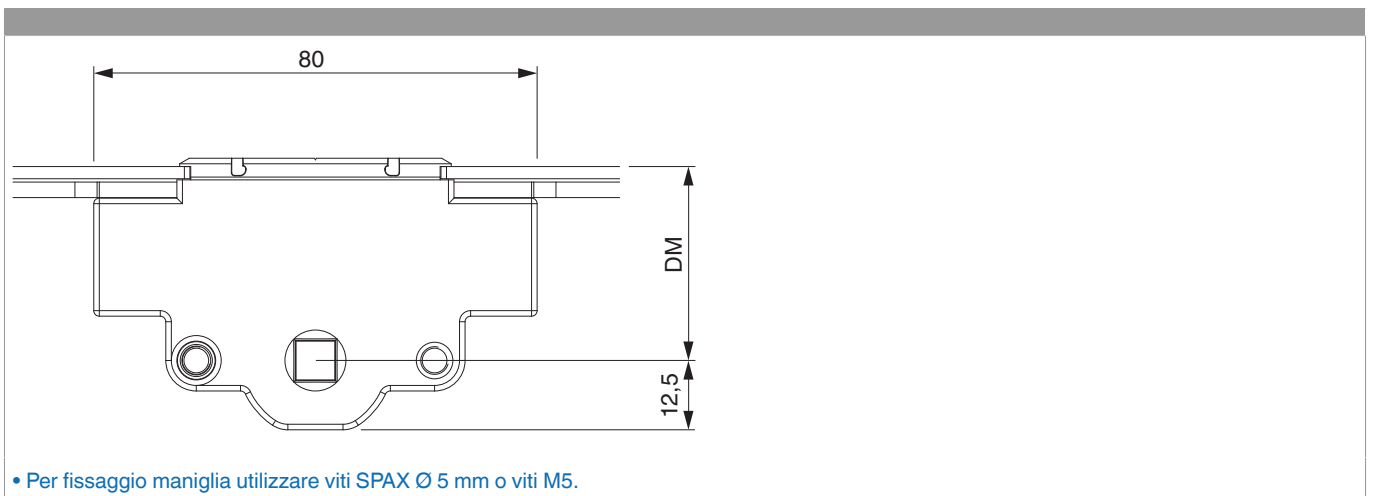

Quote scatola serratura

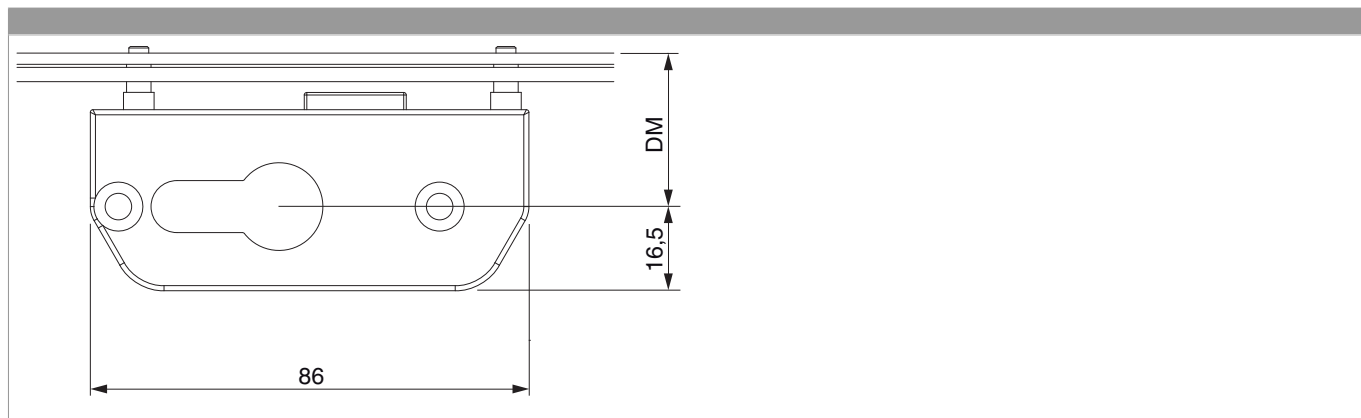

Schema di foratura

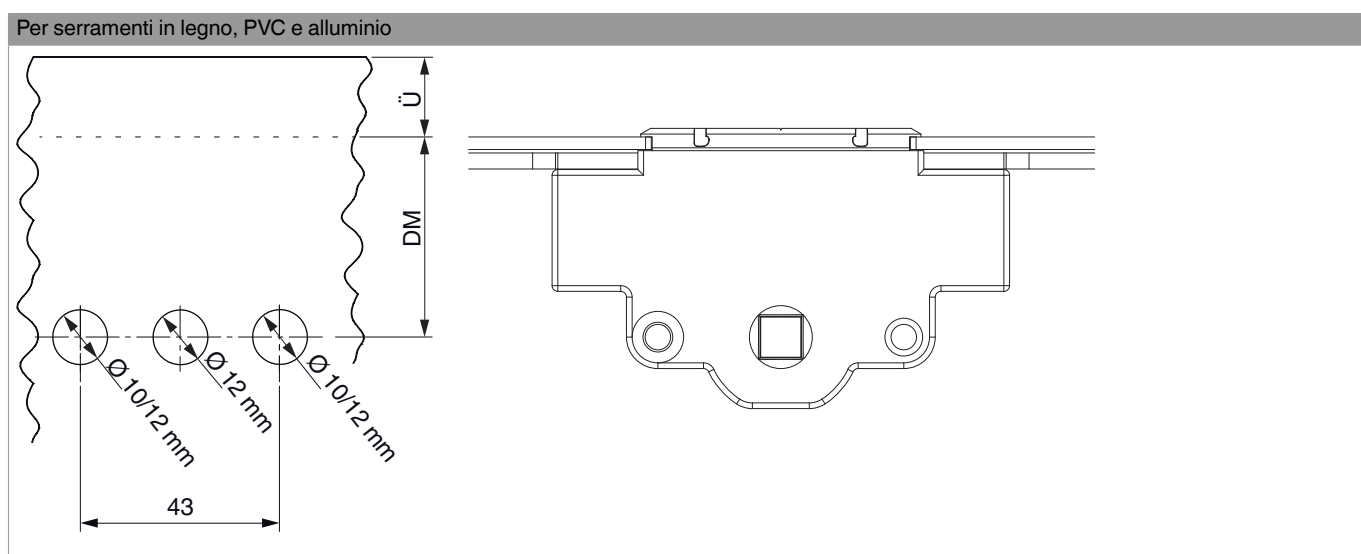

Schema foro per scatola serratura

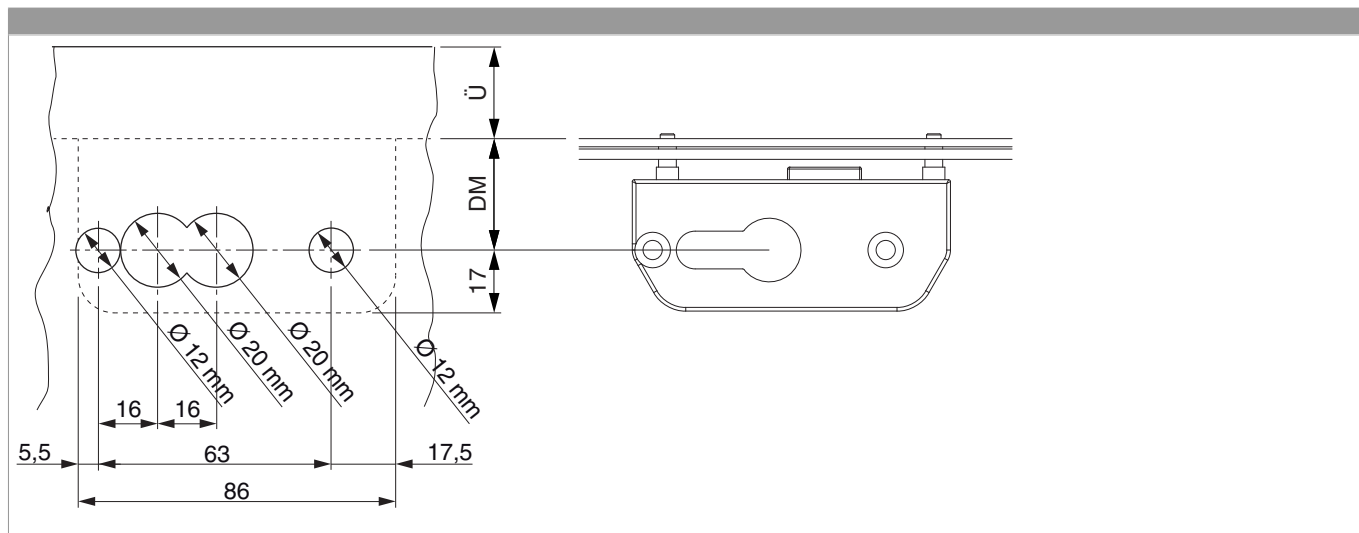

Schema di tranciatura

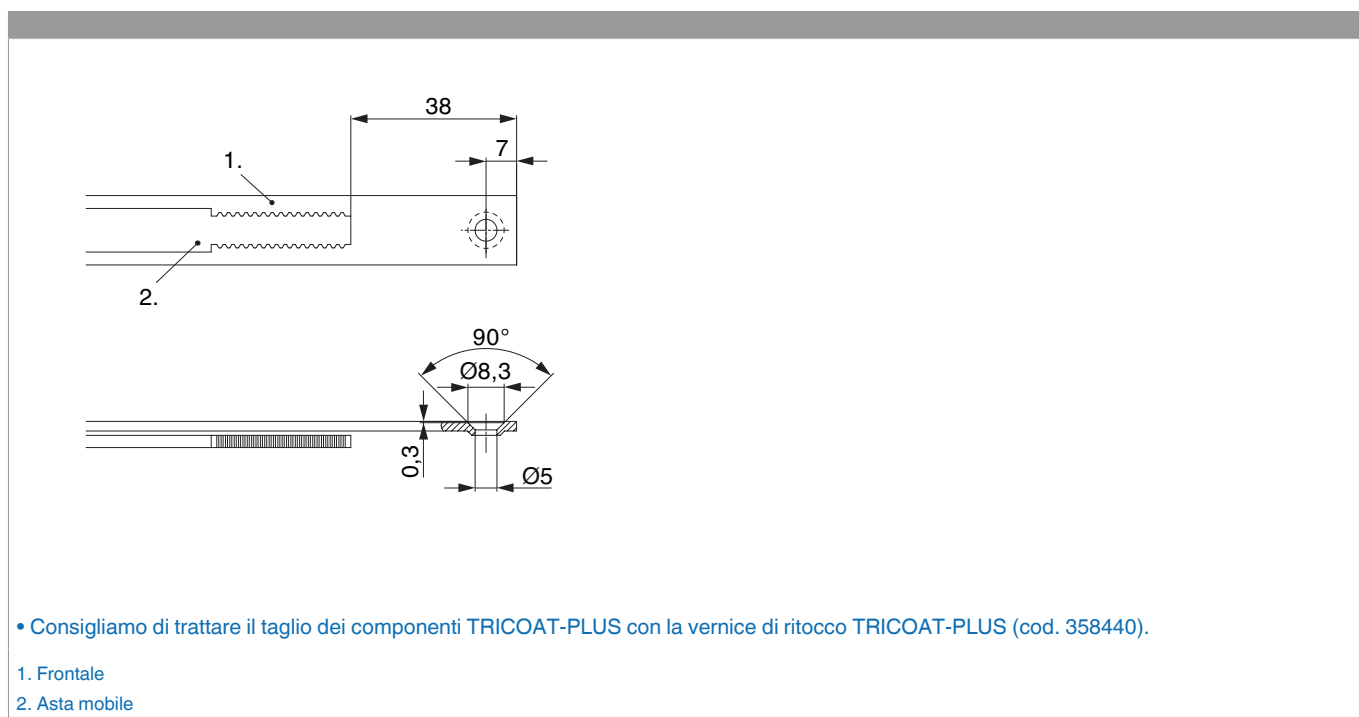

Posizionamento scontri alza anta

Scontro alza-anta A4 / senza scrocco porta

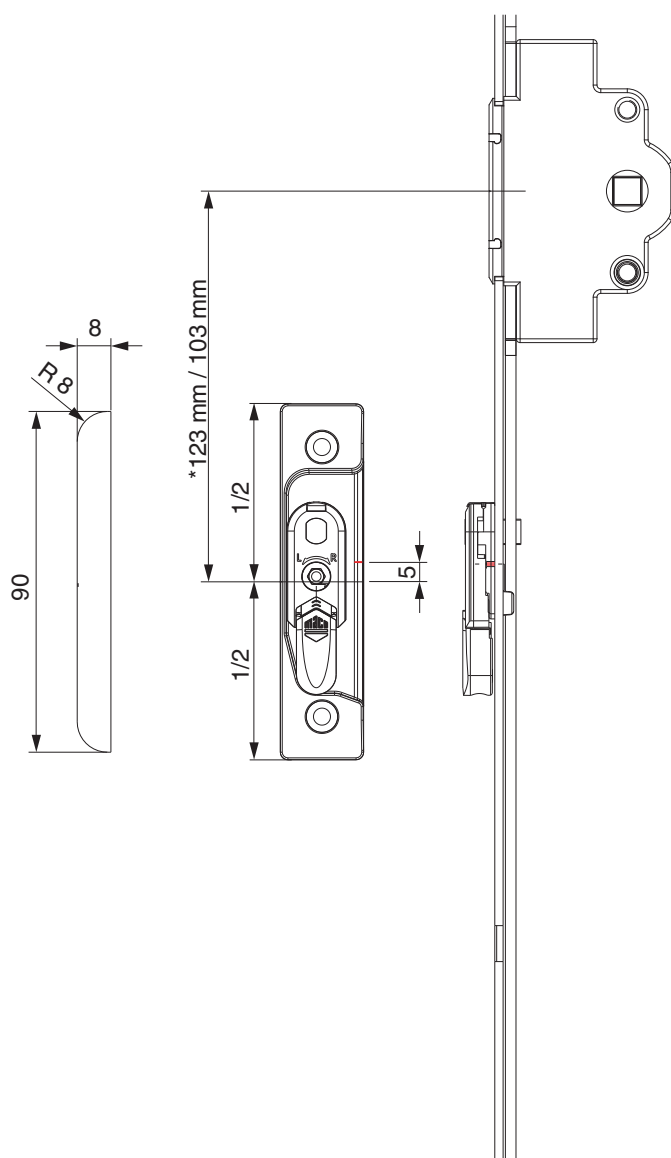

* con cremonesi grandezza 660

A12

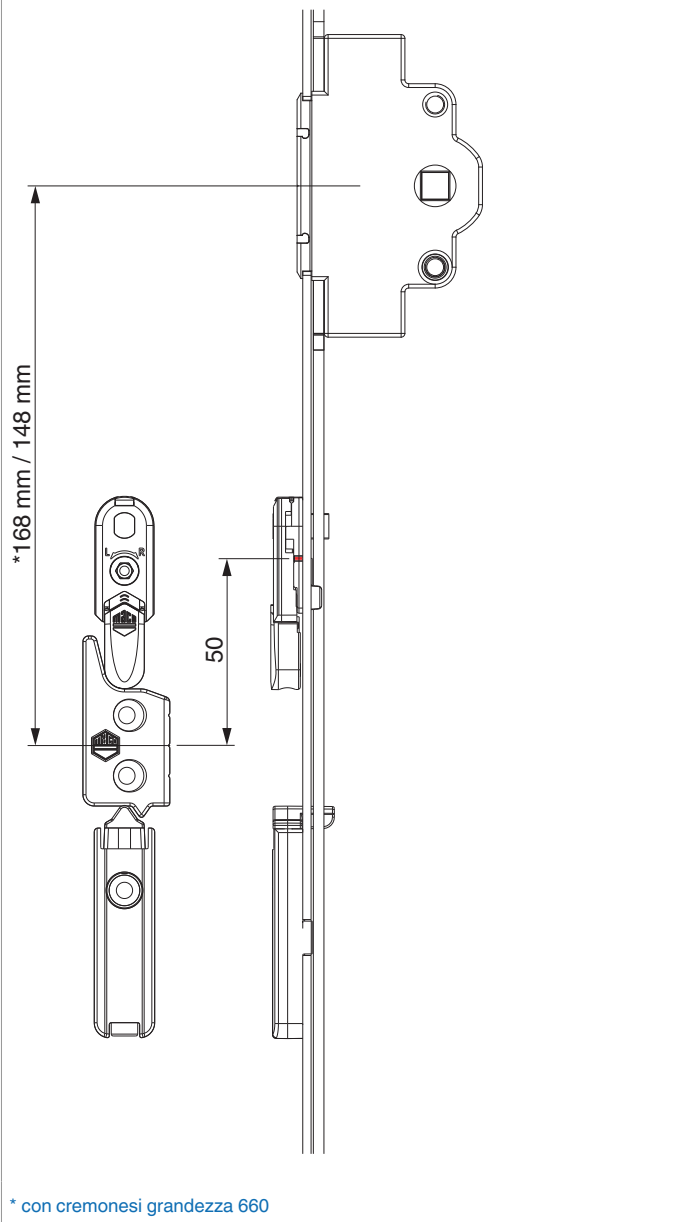

Oscillazione e regolazione in altezza dell'alza anta

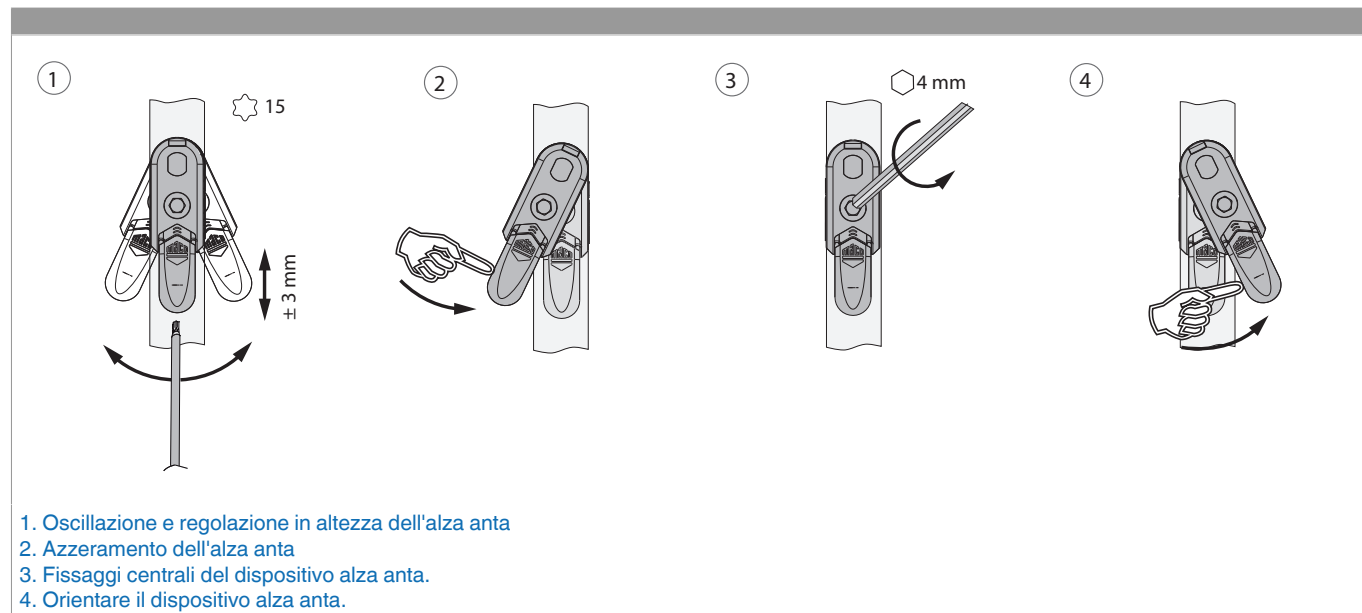

Collegamento a clips

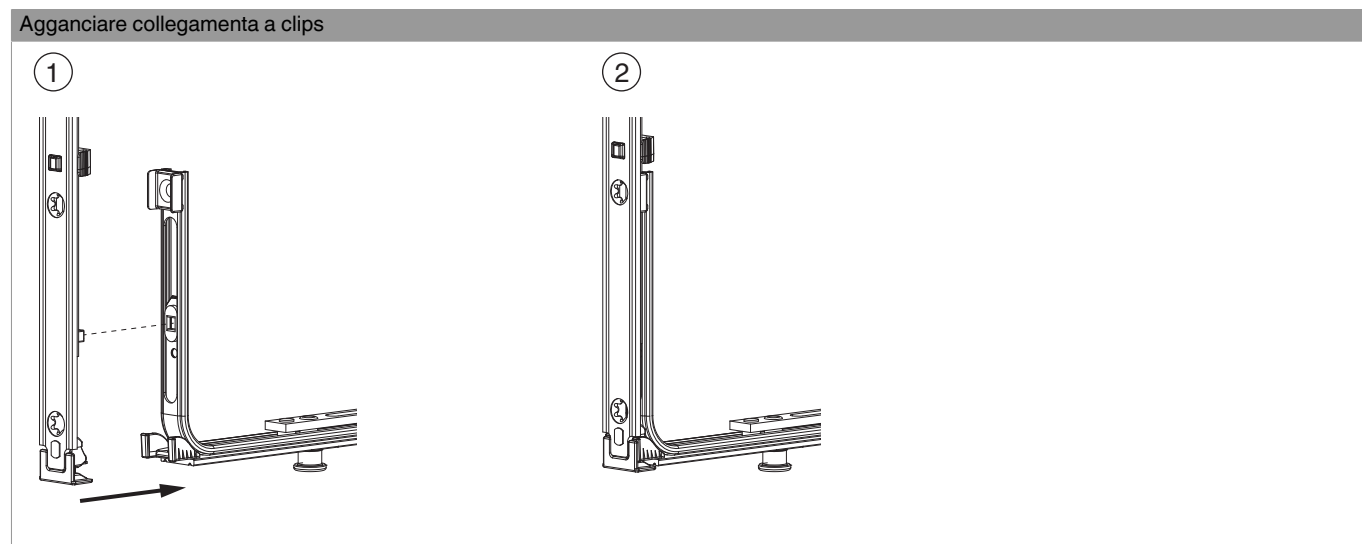

Sganciare collegamento clips

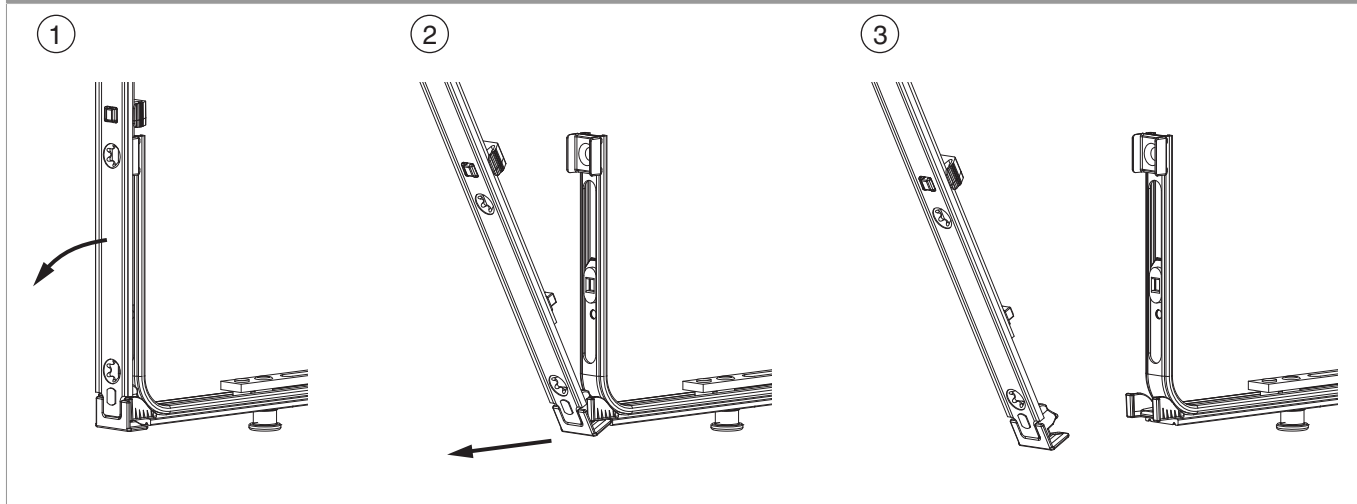

Collegamento scarpetta dentata

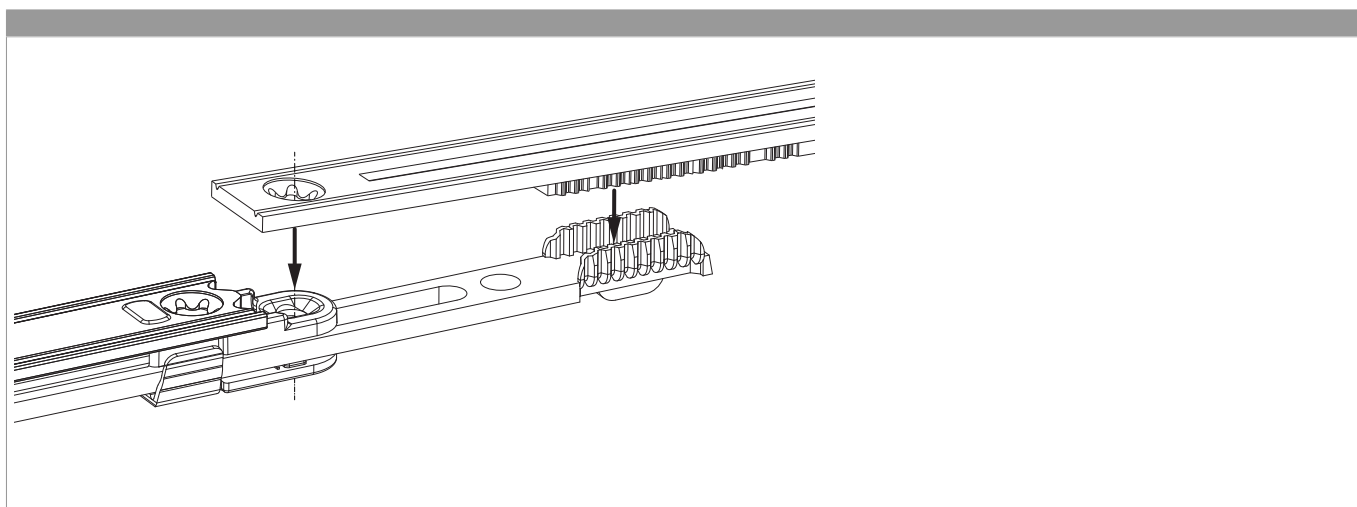

Cremonese con serratura - preparazione della finestra

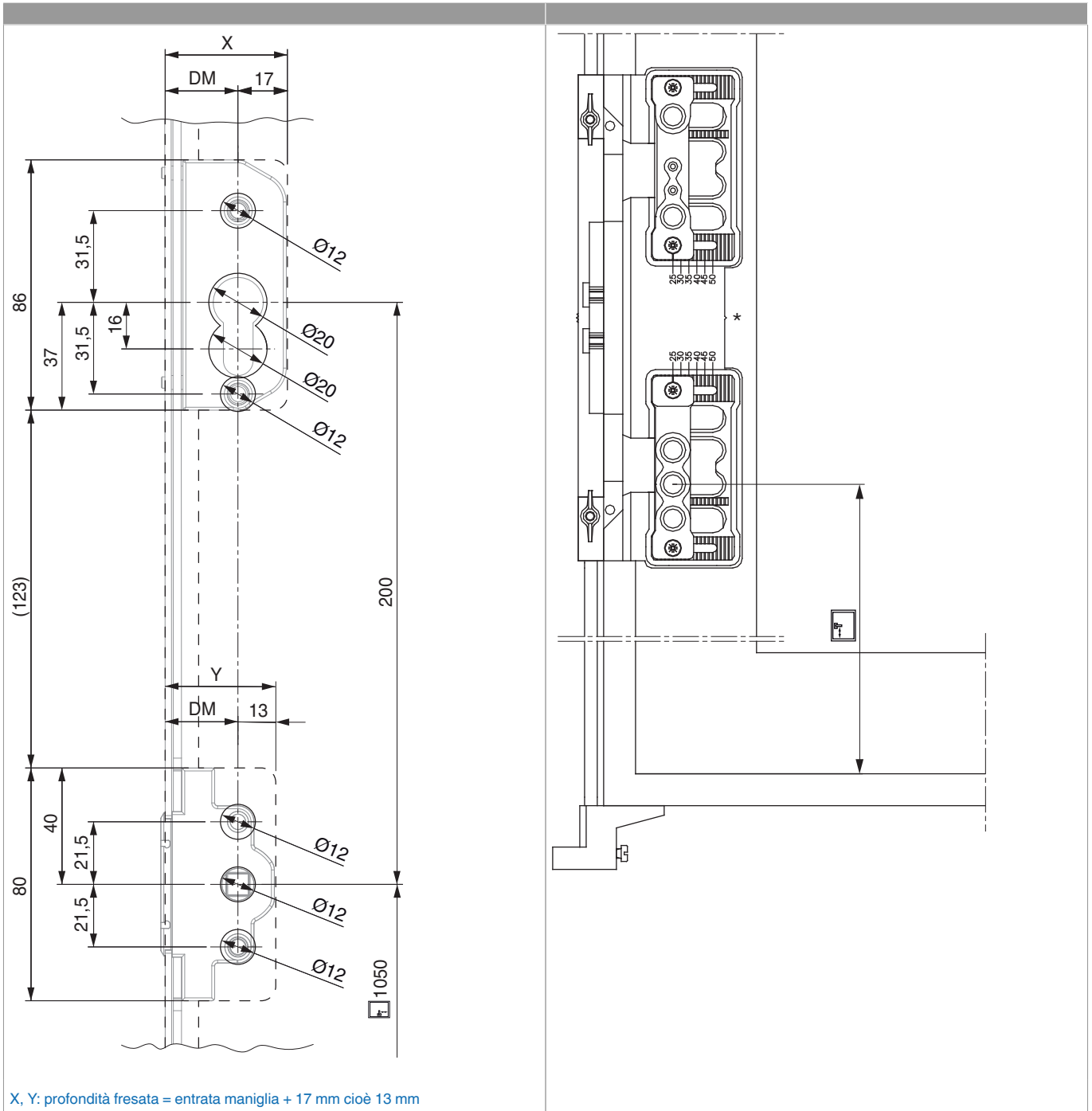

Regolazione pressione

Fungo e nottolino

