

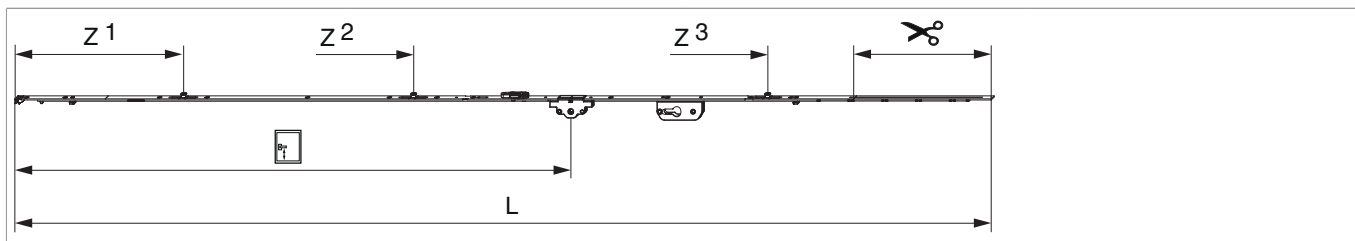

206984 - Cremonese Multi Matic 1950 E40 fix bloccabile con cilindro con 3 funghi HBB 1.701-1.950 HM1.050 argento

Disegni tecnici



| | | | | | | | | | |
|---------|------|----|-------|---------------|-------|---|----------|----|-----------|
| | | | | | | | L | | Nº |
| argento | 1950 | 40 | 1.050 | 1.701 - 1.950 | 260,5 | 1 | 1.846,5 | 10 | 206984 |

Tabella posizionamento viti

| Nº | | 1 | 2 | 3 | 4 | 5 | 6 | 7 | 8 | 9 | 10 | 11 | 12 | 13 | 14 |
|--------|----|------|------|-----|-----|-----|-----|-----|-------|-------|-------|-------|----|----|----|
| 206984 | 11 | 18,5 | 91,5 | 270 | 360 | 550 | 705 | 795 | 863,5 | 1.124 | 1.388 | 1.465 | | | |

Tabella punti di chiusura

| Nº | | Z1 | Z2 | Z3 | Z4 |
|--------|---|-----|-----|-------|----|
| 206984 | 3 | 315 | 750 | 1.420 | |

Quote della scatola cremonese

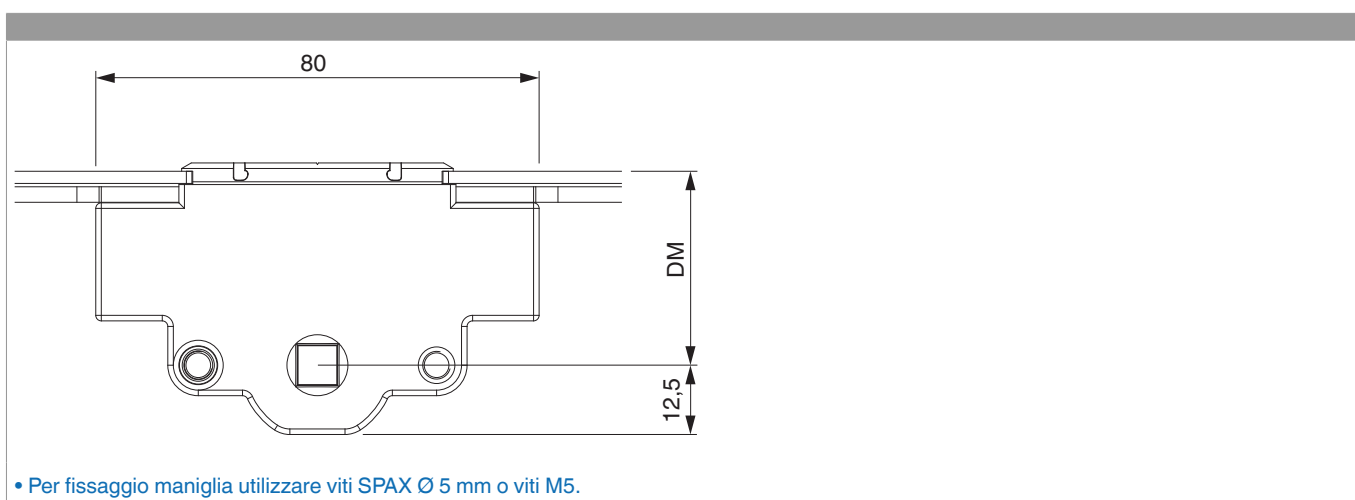



206984 - Cremonese Multi Matic 1950 E40 fix bloccabile
con cilindro con 3 funghi HBB 1.701-1.950 HM1.050
argento

Quote scatola serratura

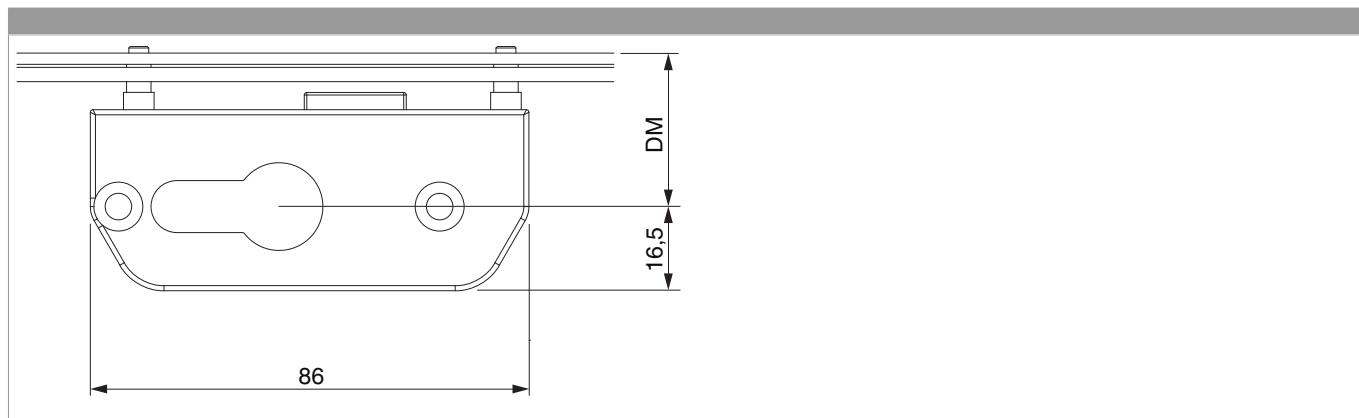

Schema di foratura

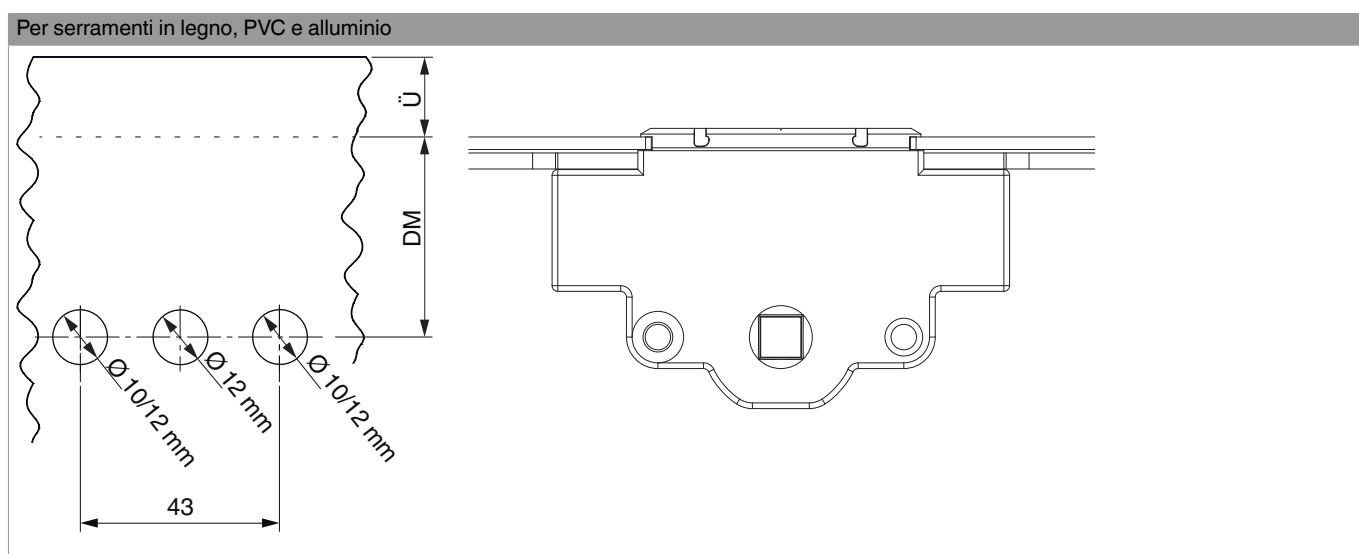



206984 - Cremonese Multi Matic 1950 E40 fix bloccabile
con cilindro con 3 funghi HBB 1.701-1.950 HM1.050
argento

Schema foro per scatola serratura

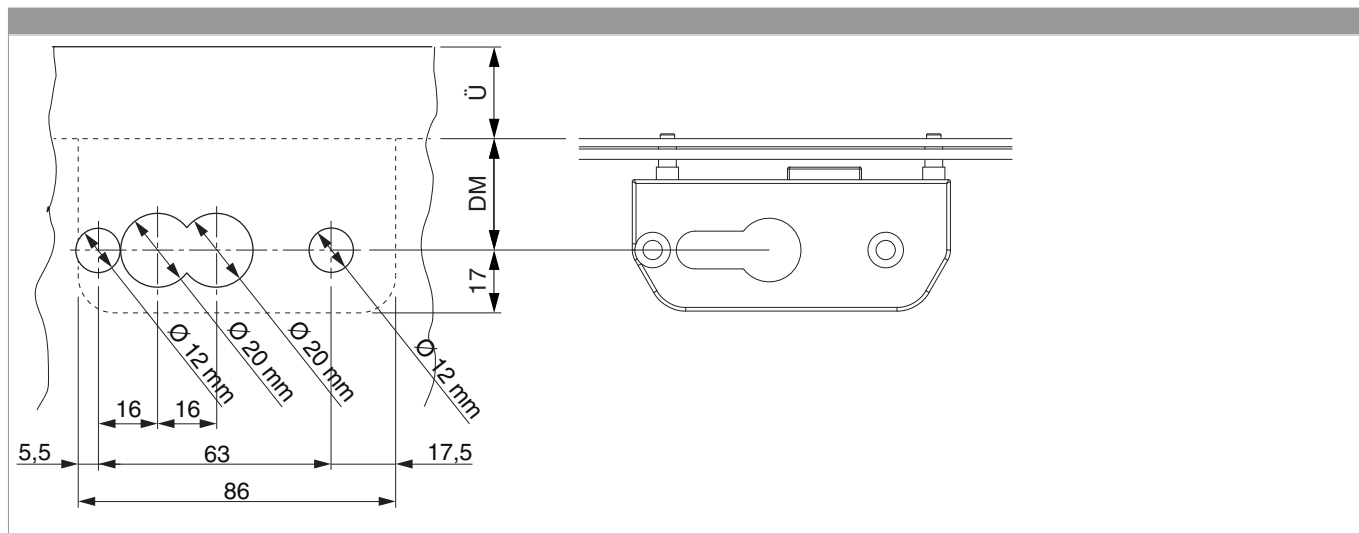



206984 - Cremonese Multi Matic 1950 E40 fix bloccabile
con cilindro con 3 funghi HBB 1.701-1.950 HM1.050
argento

Posizionamento scontri alza anta

Scontro alza-anta A4 / senza scrocco porta

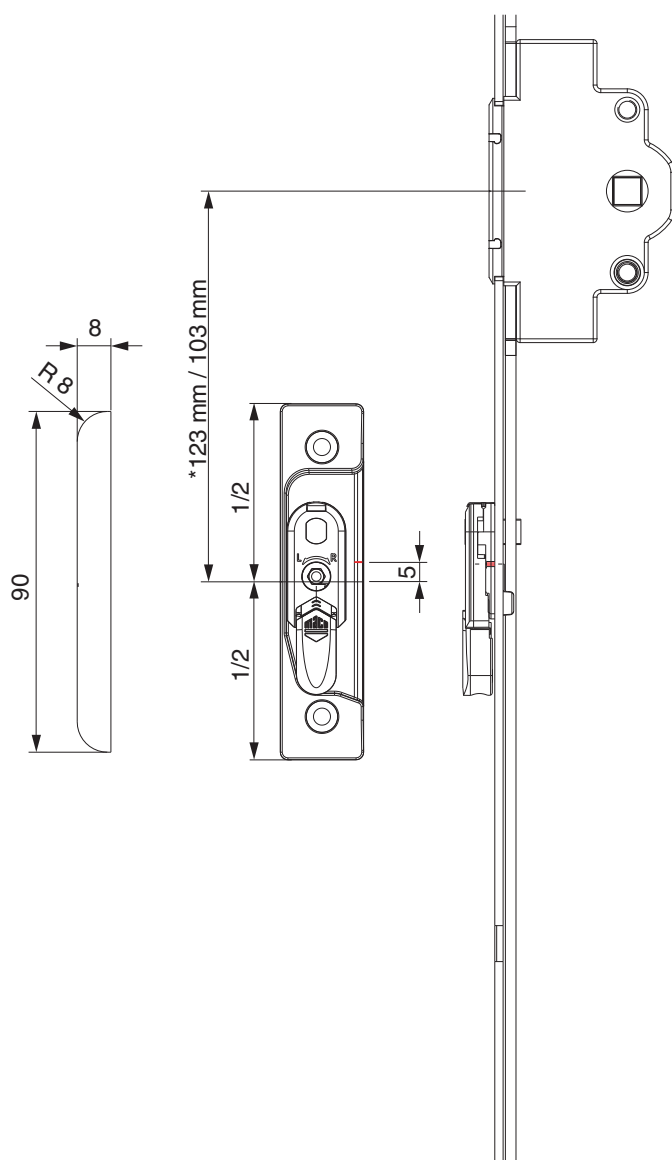

* con cremonesi grandezza 660



206984 - Cremonese Multi Matic 1950 E40 fix bloccabile
con cilindro con 3 funghi HBB 1.701-1.950 HM1.050
argento

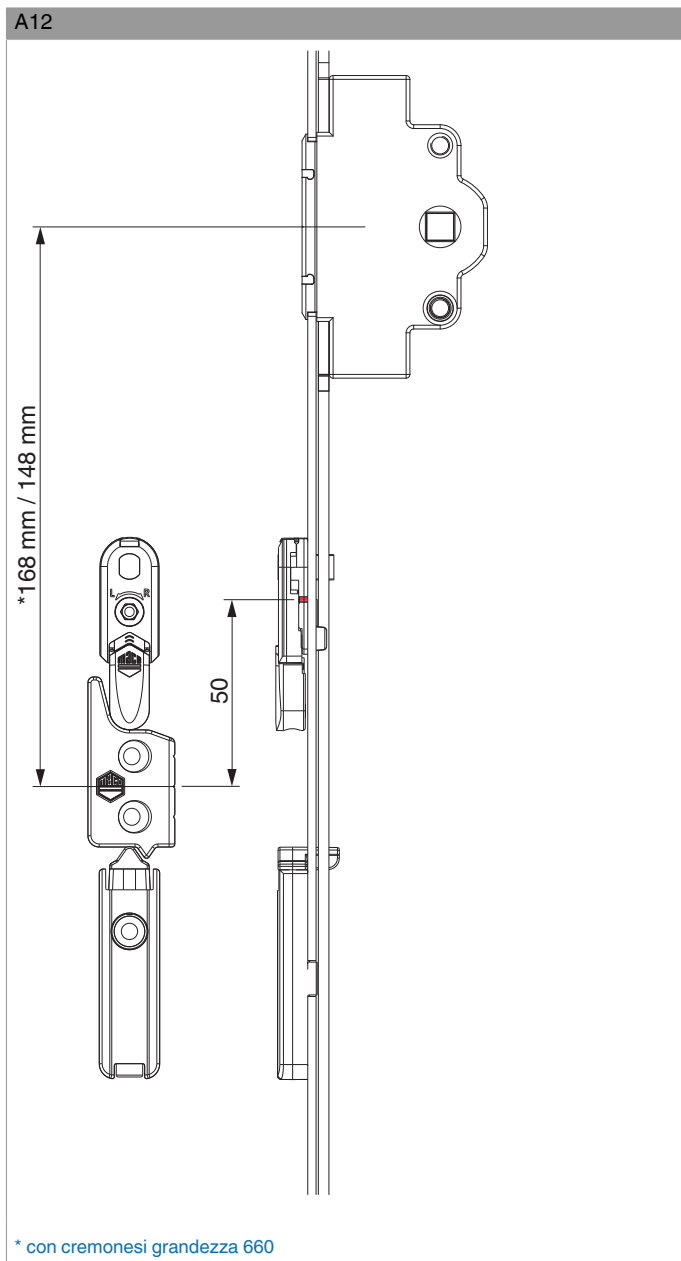



206984 - Cremonese Multi Matic 1950 E40 fix bloccabile con cilindro con 3 funghi HBB 1.701-1.950 HM1.050 argento

Schema di tranciatura

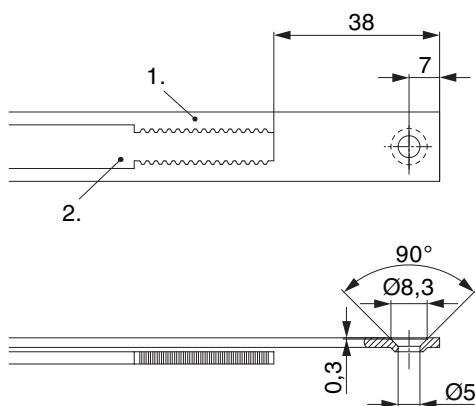

• Consigliamo di trattare il taglio dei componenti TRICOAT-PLUS con la vernice di ritocco TRICOAT-PLUS (cod. 358440).

1. Frontale
2. Asta mobile

Oscillazione e regolazione in altezza dell'alza anta

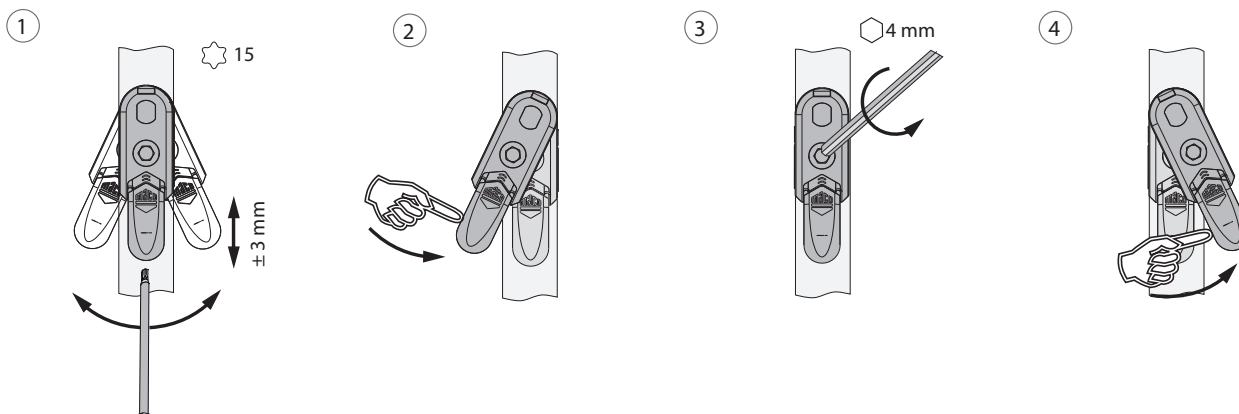

1. Oscillazione e regolazione in altezza dell'alza anta
2. Azzeramento dell'alza anta
3. Fissaggi centrali del dispositivo alza anta.
4. Orientare il dispositivo alza anta.



206984 - Cremonese Multi Matic 1950 E40 fix bloccabile
con cilindro con 3 funghi HBB 1.701-1.950 HM1.050
argento

Collegamento a clips

Agganciare collegamenta a clips

①

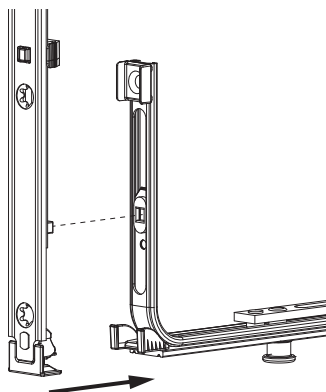

②

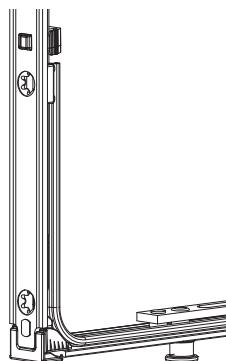

Sganciare collegamento clips

①

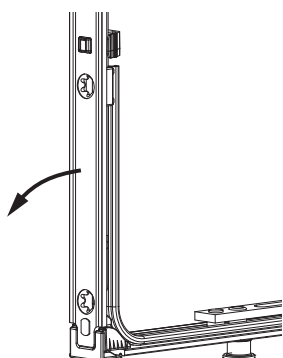

②

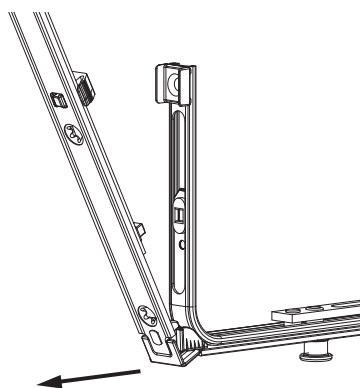

③

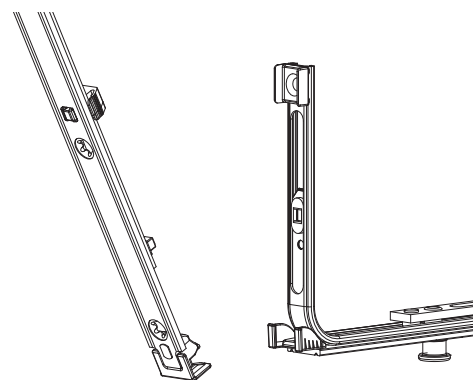



206984 - Cremonese Multi Matic 1950 E40 fix bloccabile
con cilindro con 3 funghi HBB 1.701-1.950 HM1.050
argento

Collegamento scarpetta dentata

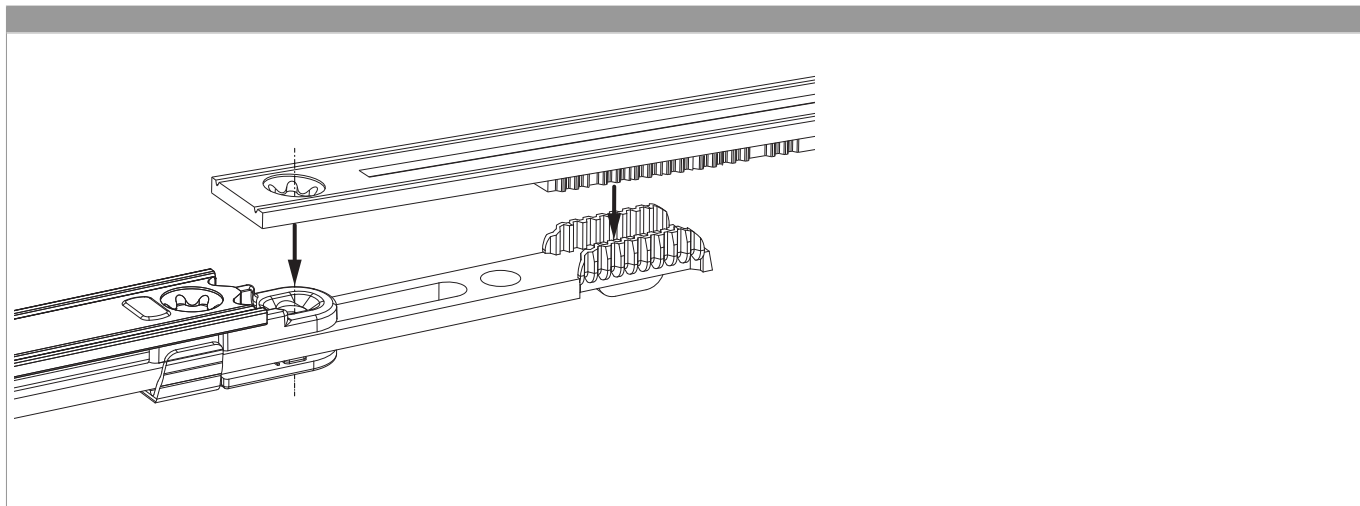



206984 - Cremonese Multi Matic 1950 E40 fix bloccabile
 con cilindro con 3 funghi HBB 1.701-1.950 HM1.050
 argento

Cremonese con serratura - preparazione della finestra

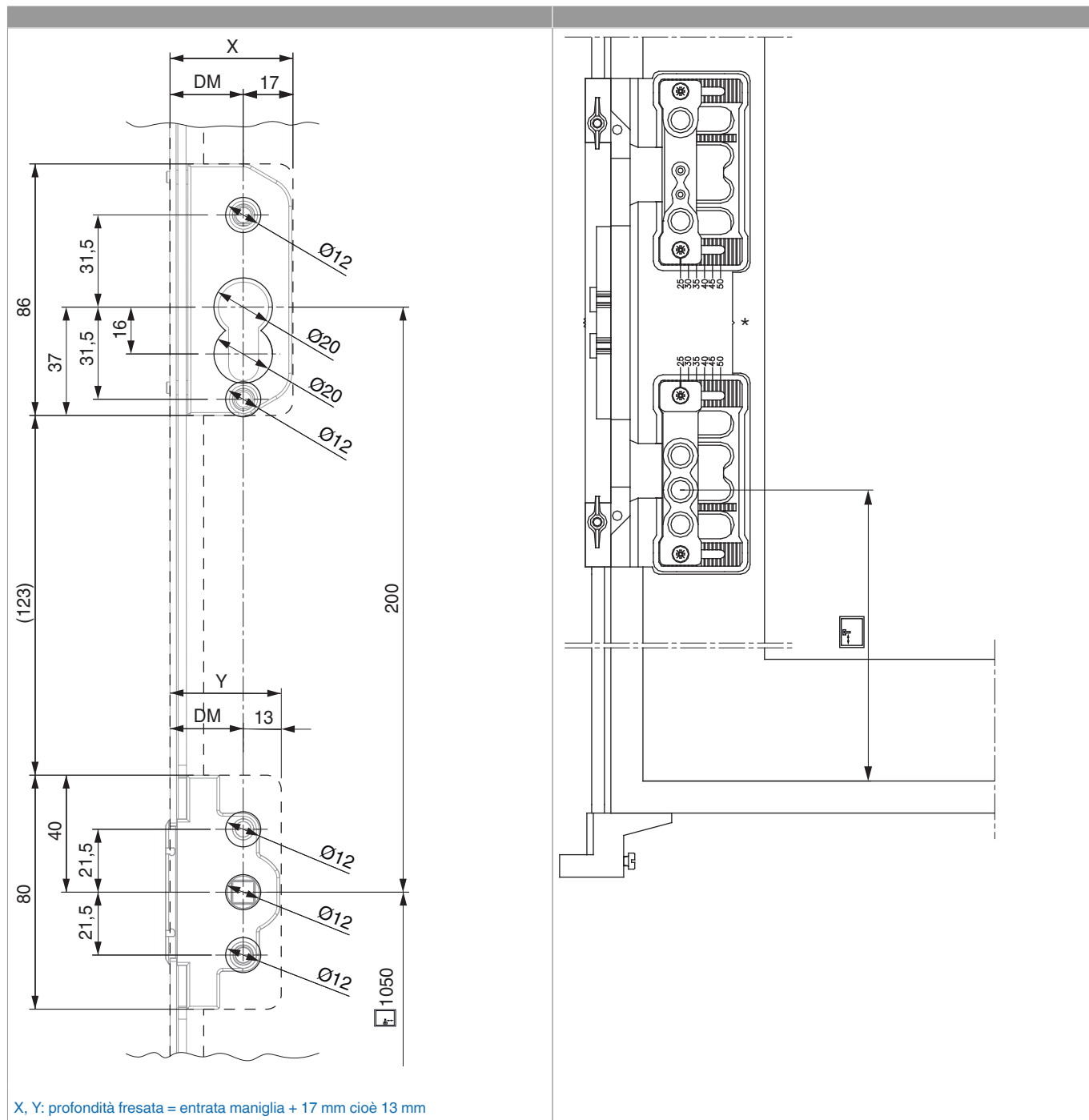



206984 - Cremonese Multi Matic 1950 E40 fix bloccabile
con cilindro con 3 funghi HBB 1.701-1.950 HM1.050
argento

Regolazione pressione

