

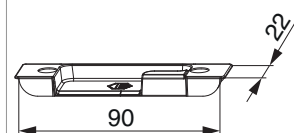



357671 - Scontro nottolino per A4 scost. 13 mm destro pressione - 1 mm argento

Disegni tecnici



				L	B	H		Nº
argento	Scontro nottolino per A4 scost. 13 mm	pressione - 1 mm	destro	90	22	8	200	357671 ¹⁾

¹⁾ Su elemento destro usare scontro sinistro e viceversa

Sezioni profilo

A4 scost.13 - 1 anta

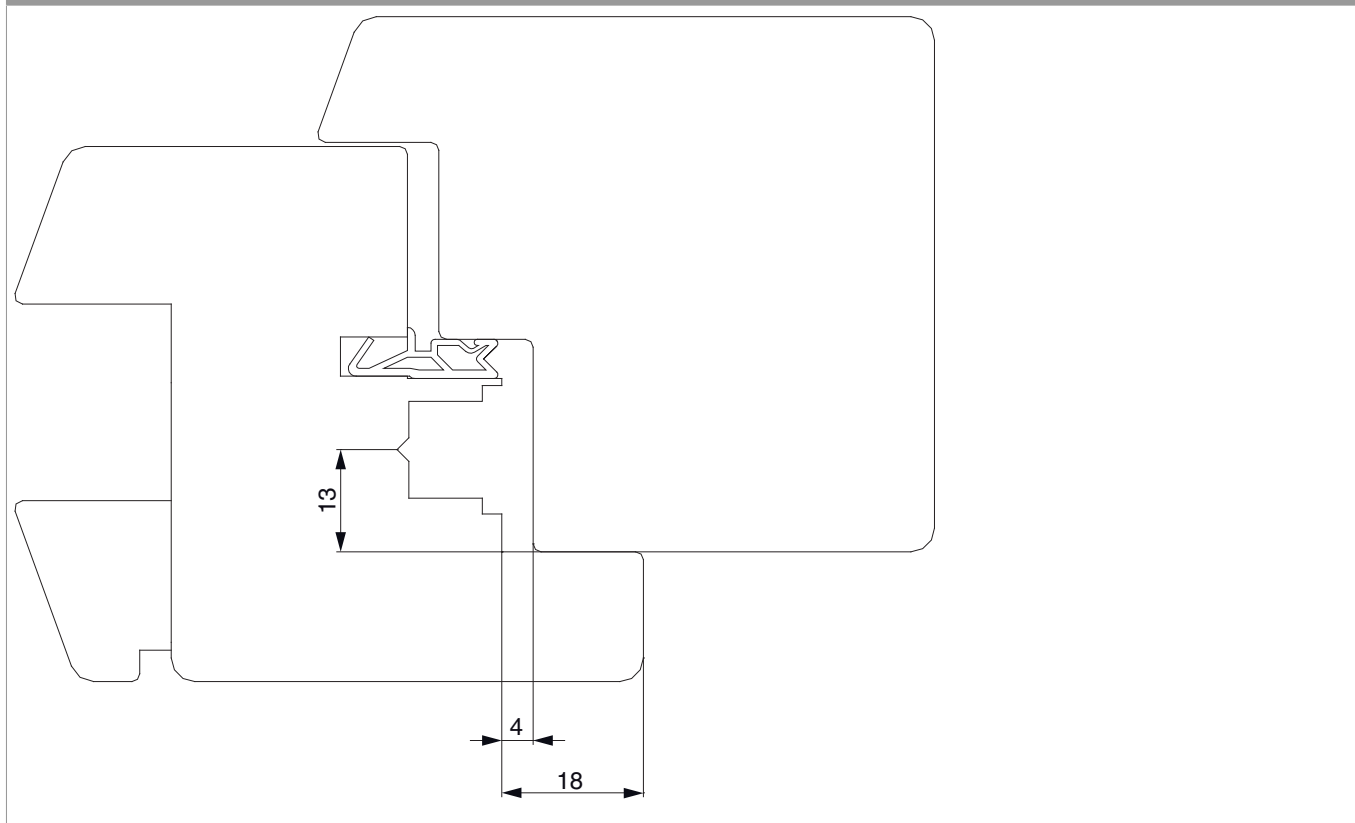

A4 scost.13 - 2 ante

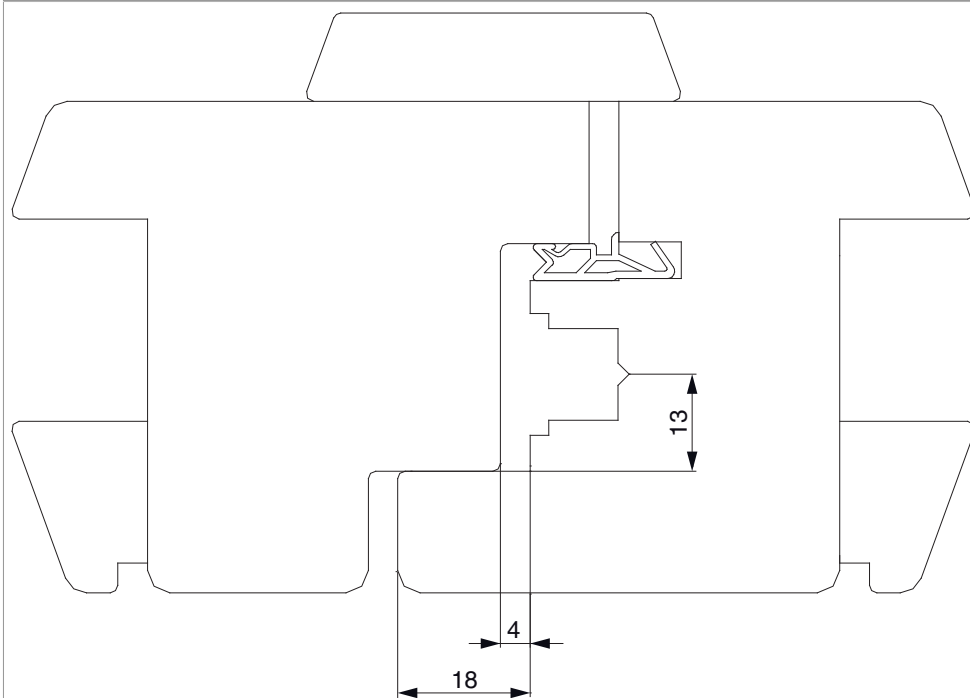

Posizionamento degli scontri

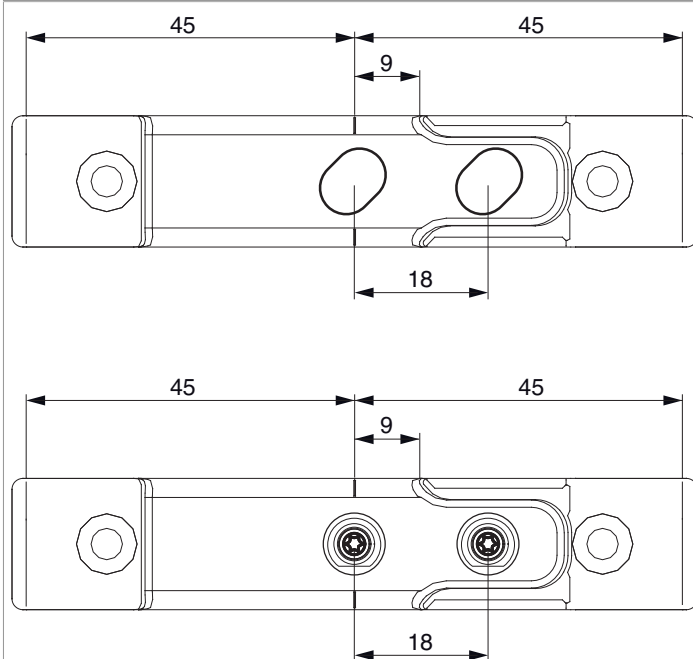

Quando si mette i scontri, si deve stare attento che il centro del nottolino e il centro dello scontro sono in linea!

Fresata

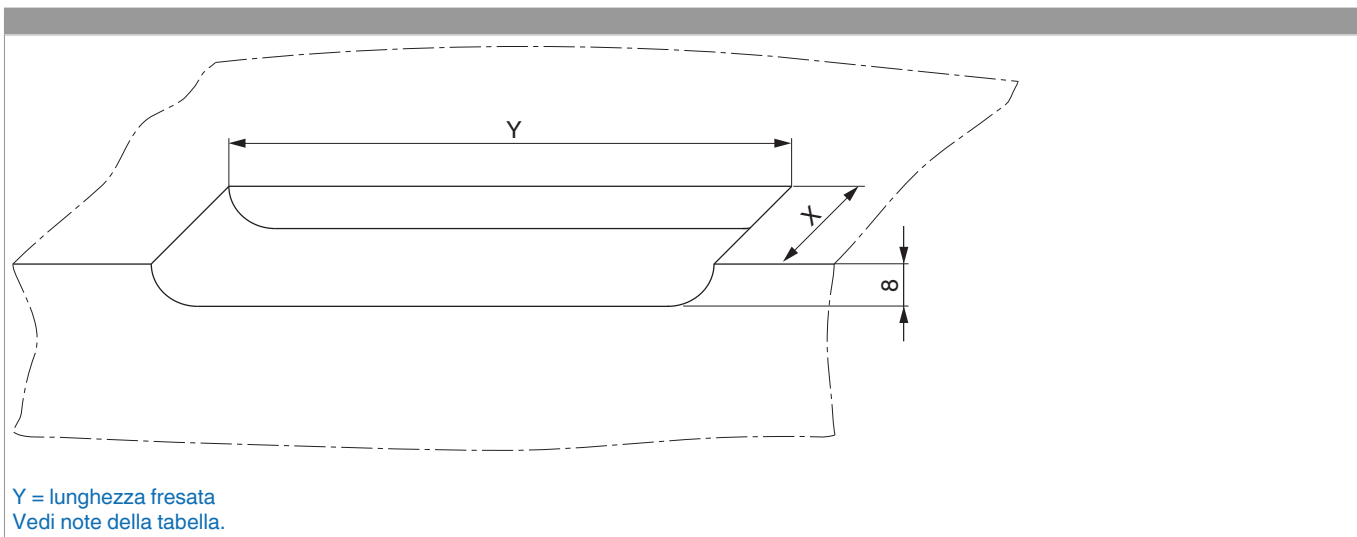

Y = lunghezza fresata
Vedi note della tabella.

Scostamento	X
scostamento 9 mm	18 mm
scost.13	22 mm