

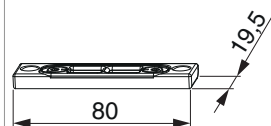

26241 - Scontro catenaccio battuta liscia/20 2 fori argento

Disegni tecnici



			L	B	H		Nº
argento	2 fori		80	19,5	6,5	100	26241

Dime

			Nº
Dima completa con guidascontro scontro catenaccio telescopica autocentrante MM-bilanciere	2 ante	1	213865

Sezioni profilo

A12 PB20 - 1 anta

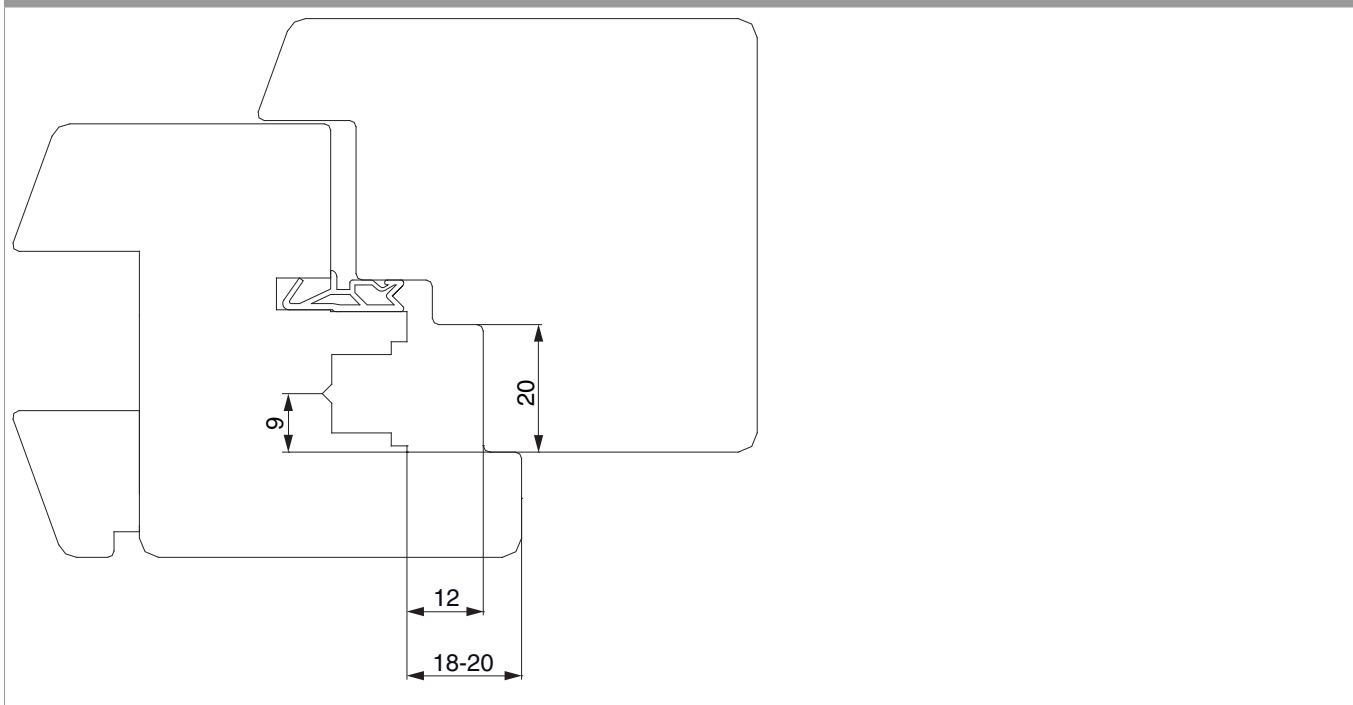



A12 PB20 - 2 ante

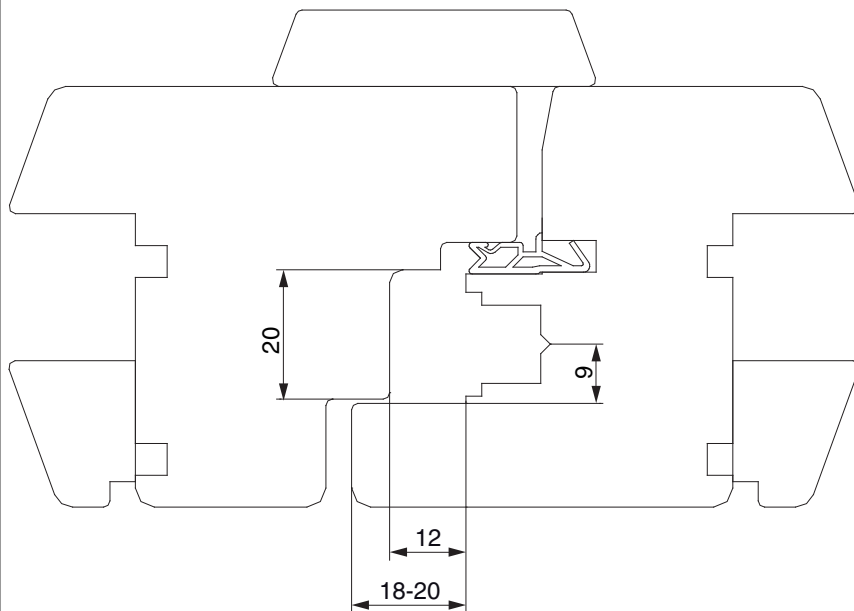

A12 PB22 - 1 anta

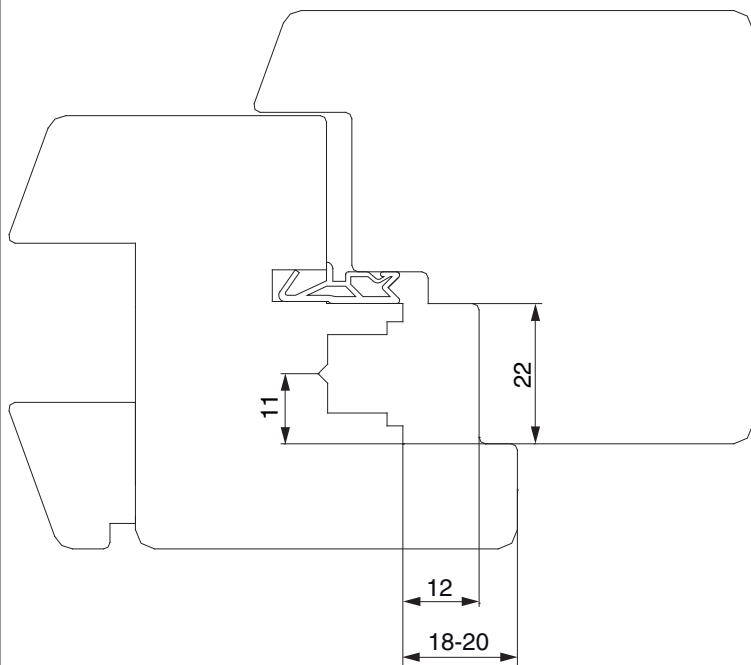



A12 PB24 - 1 anta

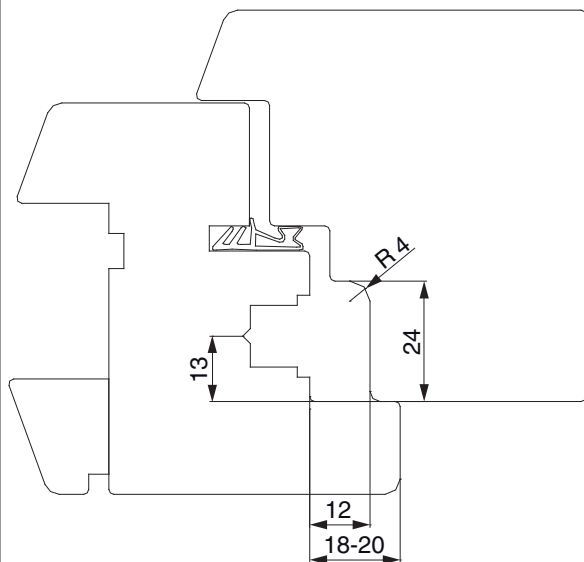

A12 PB22 - 2 ante

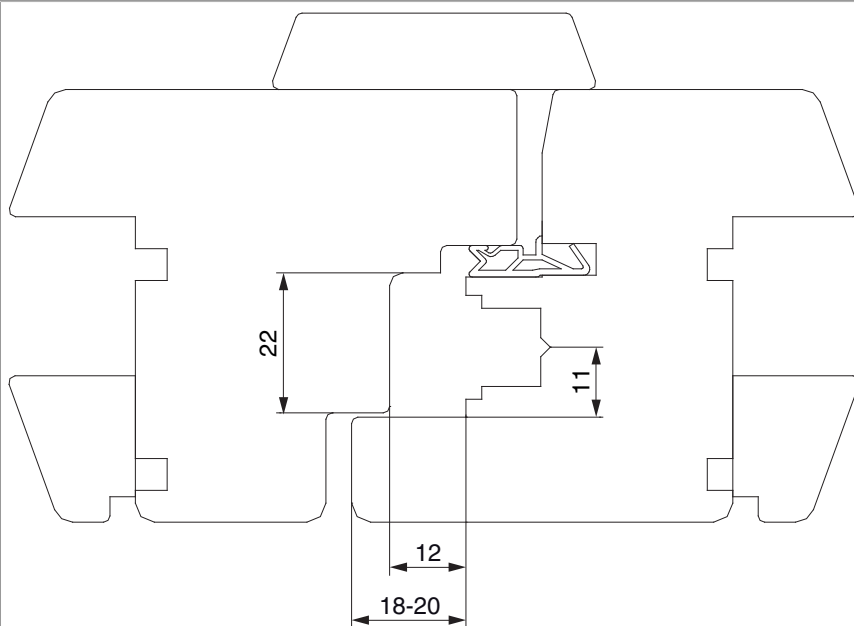

Catenaccio superiore battuta liscia argento
Catenaccio inferiore battuta liscia argento

A12 PB24 - 2 ante

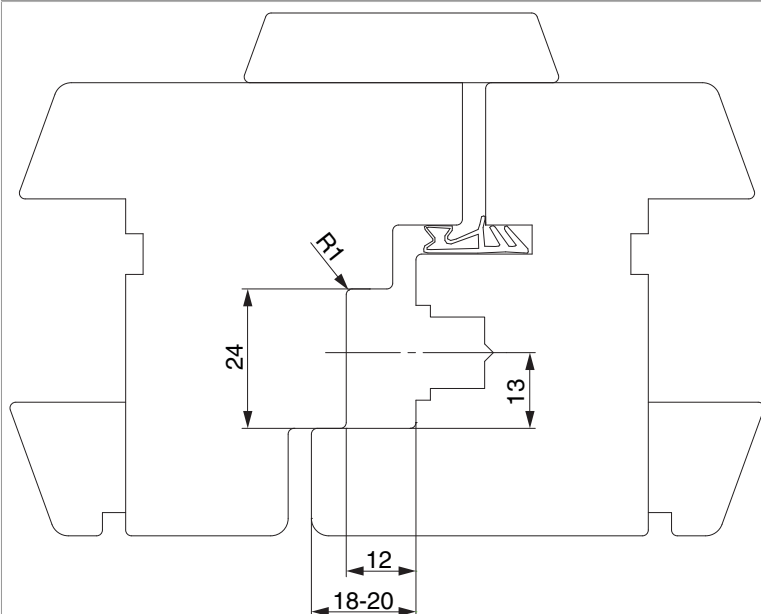

Utilizzo di catenaccio
Catenaccio superiore battuta liscia argento
Catenaccio inferiore battuta liscia argento

Raggio nella battuta max. 1 mm

L'utilizzo degli scontri A12 battuta liscia, profondità battuta 20 mm. Raggio sul fondo battuta = 1mm.

Posizionamento degli scontri

Finestra a 2 ante con 1 catenaccio

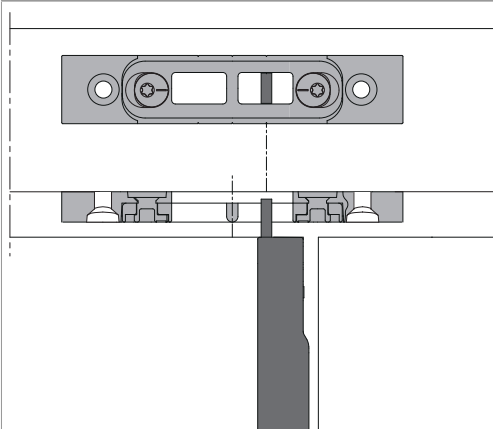

Allineare il centro dell'uscita puntale alla tacca

Finestra a 2 ante con 2 catenacci

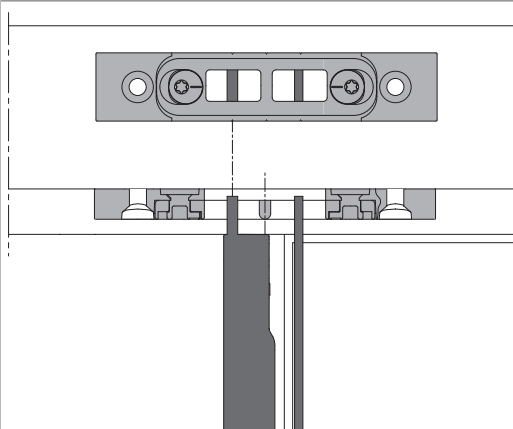

Centro scontro = centro cava ferramenta

Regolazione pressione

sullo scontro

