

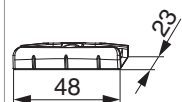

## 359297 - Scontro nottolino PB 24 mm scost. 13 mm con vite inclinata pressione - 1 mm argento

### Disegni tecnici



				L	B	H		N <sup>o</sup>
argento	Scontro nottolino PB 24 mm scost. 13 mm	con vite inclinata	pressione - 1 mm	48	23	9	200	359297

### Sezioni profilo

A12 PB24 - 1 anta

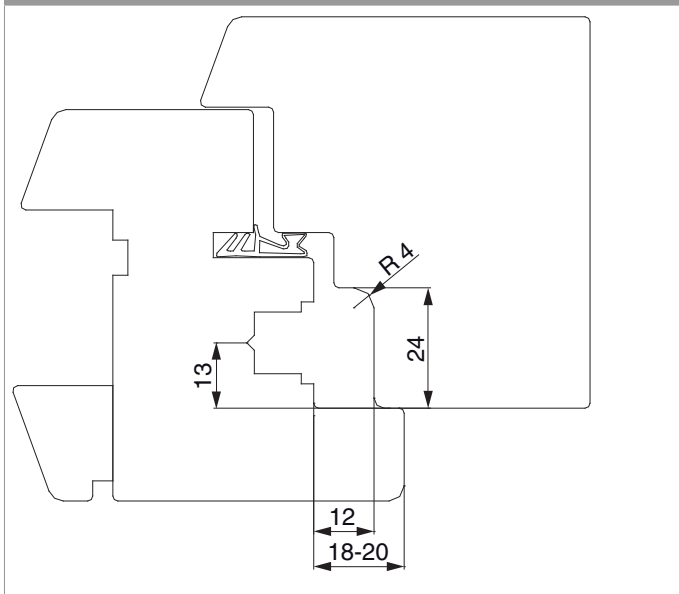



A12 PB24 - 2 ante

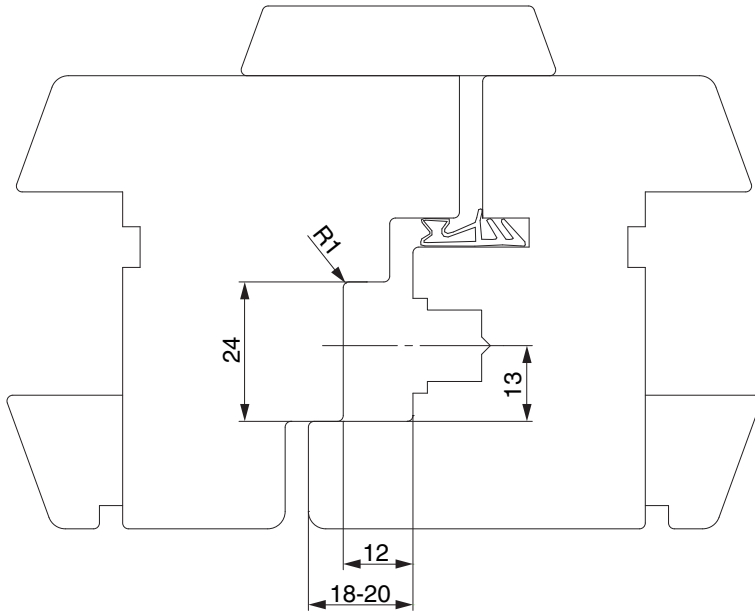

Utilizzo di catenaccio  
Catenaccio superiore battuta liscia argento  
Catenaccio inferiore battuta liscia argento

Raggio nella battuta max. 1 mm

L'utilizzo degli scontri A12 battuta liscia, profondità battuta 20 mm. Raggio sul fondo battuta = 1mm.

## Posizionamento degli scontri

