

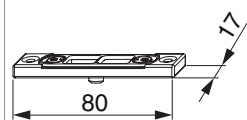

26621 - Scontro catenaccio con perno di posizionamento 12x3 mm battuta liscia/18 2 fori argento

Disegni tecnici



		L	B	H		N ^o
argento	2 fori	80	17	6,5	100	26621

Sezioni profilo

Profilato ad U in alluminio per cava ferramenta per asta a leva

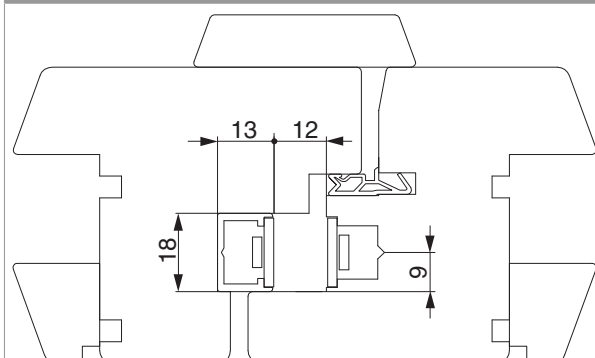

Frontale canalino euro 7/8/4

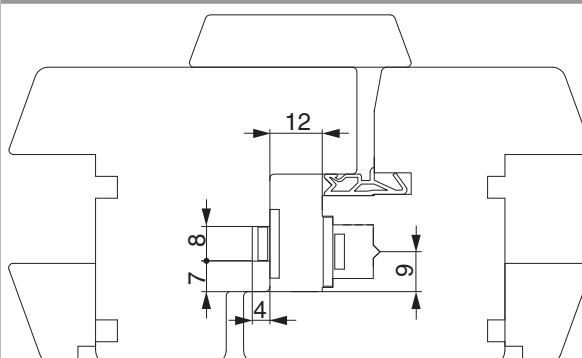

Frontale profondità battuta 18 mm, battuta liscia

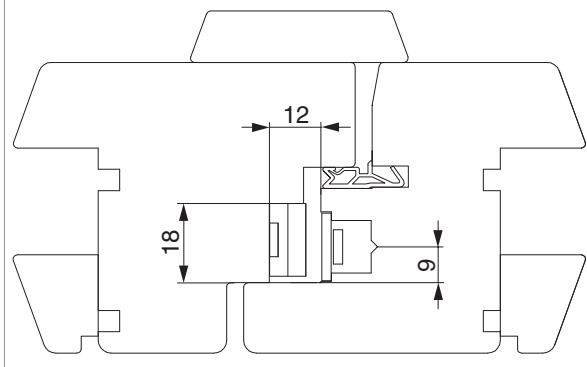



A12 battuta liscia PB18 - 1 ante

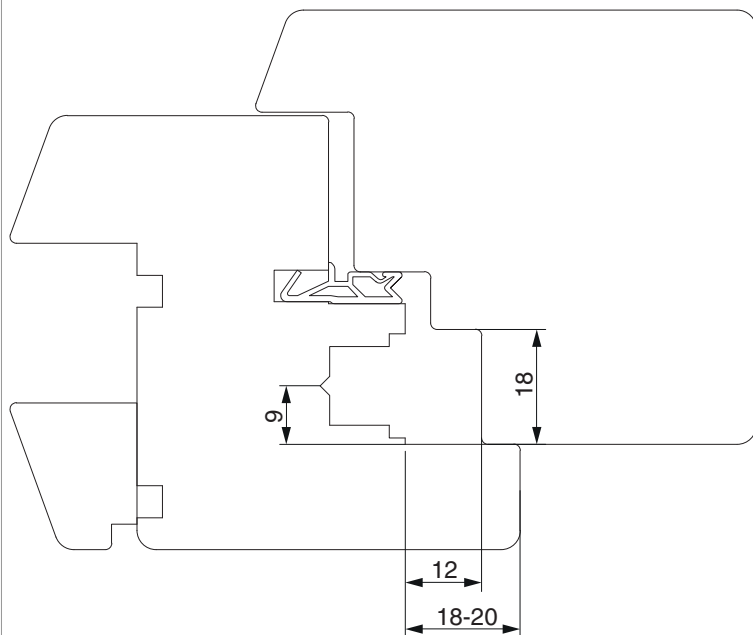

A12 battuta liscia PB18 - 2 ante

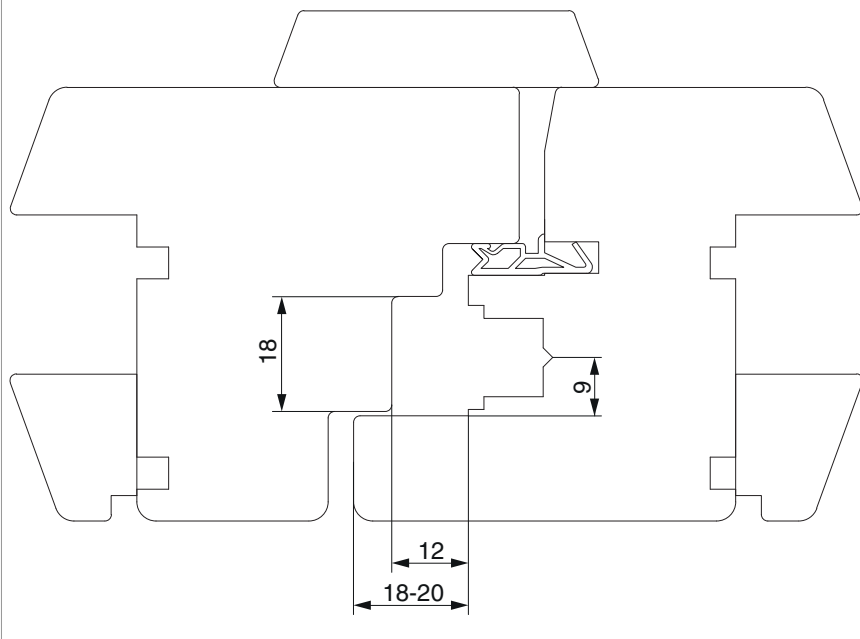



A12 battuta liscia PB20 scost.11 - 1 anta

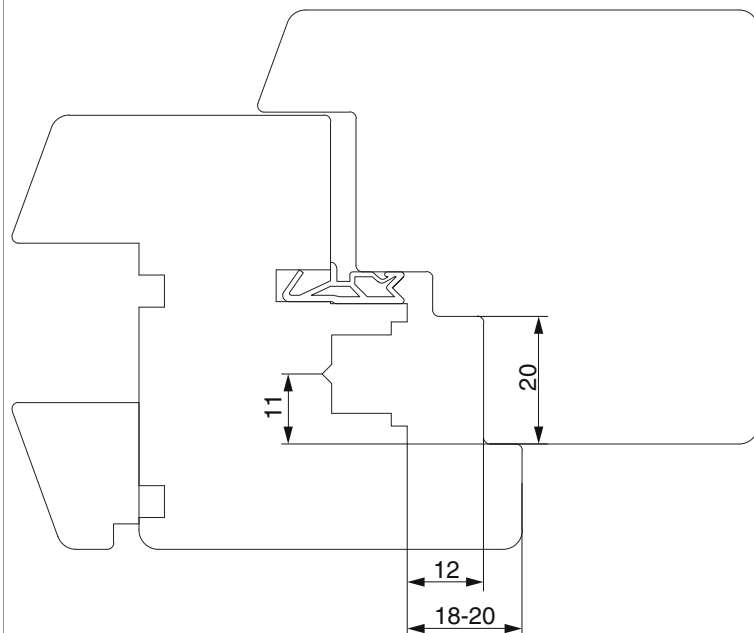

A12 battuta liscia PB20 scost.11 - 2 ante

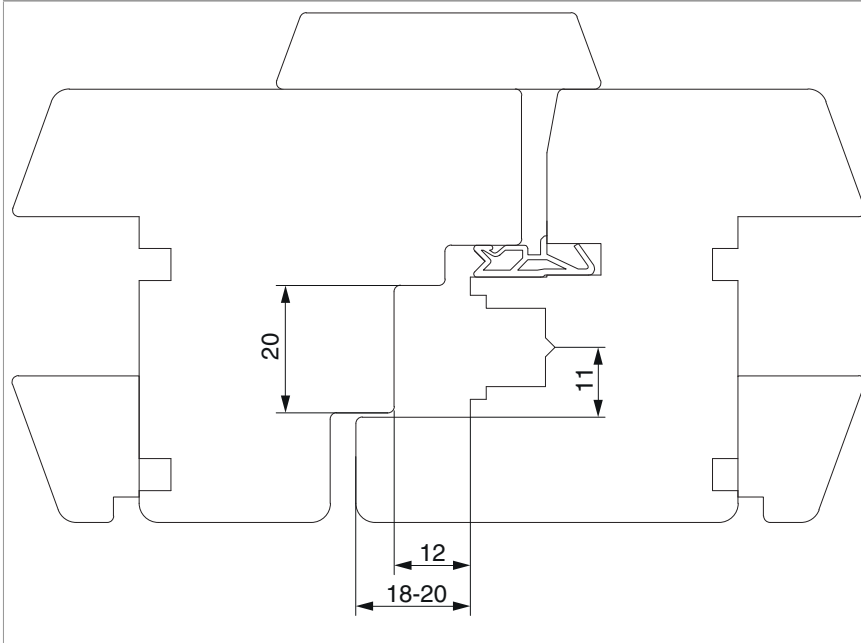

Posizionamento degli scontri

Finestra a 2 ante con 1 catenaccio

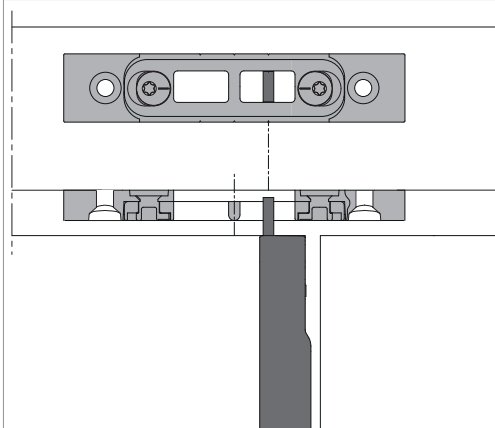

Allineare il centro dell'uscita puntale alla tacca

Finestra a 2 ante con 2 catenacci

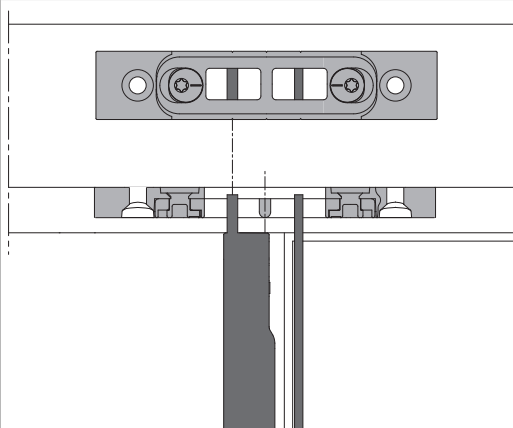

Centro scontro = centro cava ferramenta

Scontri catenaccio con perni di posizionamento

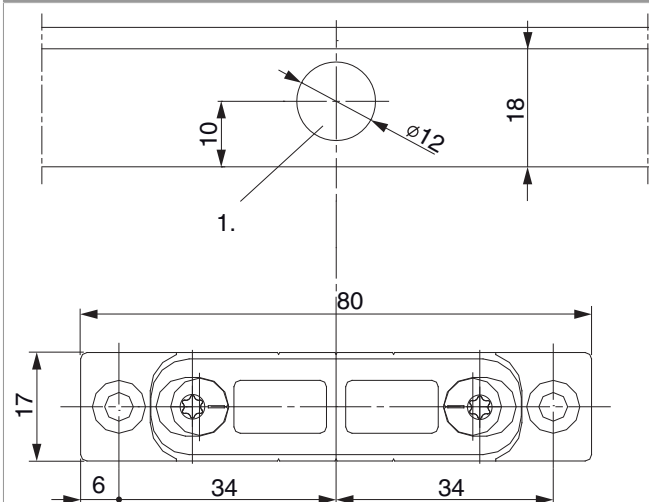

1. Profondità foratura 4 mm

Regolazione pressione

sullo scontro

